

CANADIAN BOARD OF EXAMINERS FOR PROFESSIONAL SURVEYORS

C7 – REMOTE SENSING & PHOTOGRAMMETRY

October 2022

Although programmable calculators may be used, candidates must show all formulae used, the substitution of values into them, and any intermediate values to 2 more significant figures than warranted for the answer. Otherwise, full marks may not be awarded even though the answer is numerically correct.

Note: This examination consists of 10 questions on 4 pages.

Q. No

Time: 3 hours

Marks

Value Earned

1.	a) What is meant by a metric “digital camera”? b) Briefly explain the following terms and how they are evaluated for a digital imaging system: 1) Geometric resolution, 2) Radiometric resolution, 3) Spectral resolution, and 3) Temporal resolution. c) Where in the image is there no atmospheric refraction distortion? Why? d) Why do we use the term “Pseudo Range” to denote the measured range by a GPS/GNSS receiver?	2 4 2 2	
2.	The Figure below shows a 3D schematic diagram of a building and the associated ground coordinate system (in black – upper case XYZ) as well as the image/camera coordinate systems for two images (in grey – lower case xyz) that have been captured around the building. What will be the approximate values you would use for the rotation angles (ω , ϕ , and κ) for these images in a bundle adjustment procedure? Why? Would you expect any problem in the estimation of these rotation angles in the bundle adjustment procedure? Why?	10	

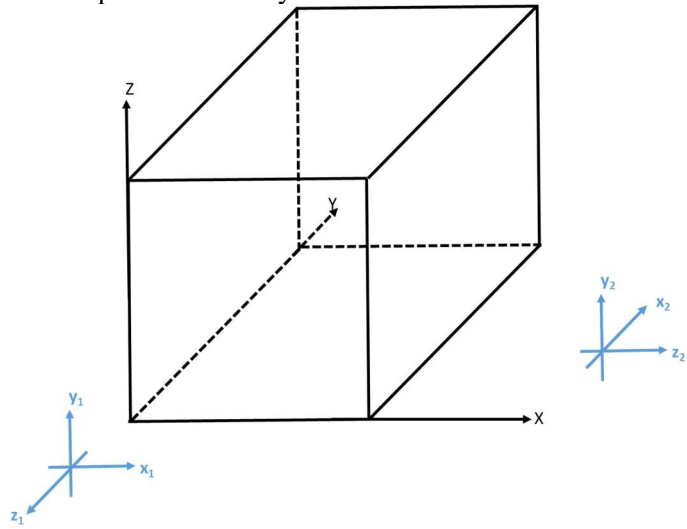

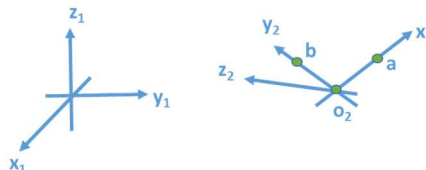
3.	<p>What is the rotation matrix that relates the coordinate systems, which share the same origin, in the figure below – given that $r_{o_2 a}^{x_1 y_1 z_1} = [-4 \ 3 \ 5]^T$ and $r_{o_2 b}^{x_1 y_1 z_1} = [4 \ -3 \ 5]^T$? Briefly explain how did you derive such a rotation matrix.</p> <p>Note:</p> <ul style="list-style-type: none"> • $r_{o_2 a}^{x_1 y_1 z_1}$ denotes the components of the vector $o_2 a$ w.r.t. the $x_1 y_1 z_1$ coordinate system • $r_{o_2 b}^{x_1 y_1 z_1}$ denotes the components of the vector $o_2 b$ w.r.t. the $x_1 y_1 z_1$ coordinate system 	10	
4.	<p>What is the <u>minimum number</u> and <u>optimal configuration</u> of ground control points that are needed for (justify your answer):</p> <ul style="list-style-type: none"> • Dependent relative orientation of a stereo-pair, • Independent relative orientation of a stereo-pair, • Single photo resection, • Indirect geo-referencing of an image stereo-pair, and • Indirect geo-referencing of an image block with 60% overlap and 60% side lap? 	8	
5.	<p>a) Explain how you can use the spectral reflectance curve to identify the moisture content in vegetation and soil.</p> <p>b) One can argue that digital cameras can see through shadow. Do you agree with this statement? Why?</p> <p>c) What is the dynamic range of a color (RGB) digital camera that has 27 bits/pixel?</p> <p>d) What are the parameters that are solved for in the following photogrammetric problems: 1) Single photo resection; 2) Photogrammetric intersection; 3) Bundle adjustment; 4) Bundle adjustment with self-calibration; 5) Dependent relative orientation for a stereo-pair; and 6) Independent relative orientation for a stereo-pair)?</p>	2 2 2 6	

6.	<p>a) Starting from the Collinearity equations, derive the mathematical model associated with vertical photography. In other words, starting from the equations below for a general image:</p> $x_a = x_p - c \frac{r_{11}(X_A - X_o) + r_{21}(Y_A - Y_o) + r_{31}(Z_A - Z_o)}{r_{13}(X_A - X_o) + r_{23}(Y_A - Y_o) + r_{33}(Z_A - Z_o)} + distortion_{x_a}$ $y_a = y_p - c \frac{r_{12}(X_A - X_o) + r_{22}(Y_A - Y_o) + r_{32}(Z_A - Z_o)}{r_{13}(X_A - X_o) + r_{23}(Y_A - Y_o) + r_{33}(Z_A - Z_o)} + distortion_{y_a}$ <p>Derive the equations below for vertical photography (In your derivation, clearly state the assumptions you are making):</p> $x_a = c * \frac{X_A}{H-h_A} \text{ and } y_a = c * \frac{Y_A}{H-h_A}$ <p>b) The overlap percentage between successive images along a given flight line does not change. Do you agree with this statement? Why?</p> <p>c) One needs at least three GNSS satellites for single point positioning using pseudo ranges. Do you agree with this statement? Why?</p>	8 2 2	
7.	<p>a) Height estimation using relief displacement measurements of objects closer to the nadir point is more precise than those that are farther. Do you agree with this statement? Why?</p> <p>b) How many collinearity equations can be established for an object point that has been observed in four images? What is the redundancy when estimating the ground coordinates of the object point? State any assumptions made in this calculation.</p> <p>c) What are the main characteristics/differences between supervised and unsupervised classification strategies? <u>Tabulate your answer.</u></p> <p>d) Image residuals from a bundle adjustment procedure are always very small. Do you agree with this statement? Why?</p>	2 3 3 2	
8.	<p>a) What are the image formation principles used for deriving the lens equation ($1/\text{image distance} + 1/\text{object distance} = 1/\text{focal length}$)?</p> <p>b) How far is the principal point from the nadir point for a vertical image?</p> <p>c) List three advantages of increasing the overlap/side lap in an image block.</p> <p>d) List three reasons for GNSS/INS integration for direct geo-referencing of an imaging system.</p>	2 1 3 3	
9.	<p>a) How is the perspective center defined for the lens assembly of a digital camera system?</p> <p>b) The light ray from an object point to its corresponding image point is a straight line. Do you agree with this statement? Why?</p> <p>c) What is the objective of establishing the interior orientation for a given camera? List the interior orientation parameters that we usually solve for. What are the alternative methodologies for deriving the interior orientation parameters of a photogrammetric camera? Which one would you prefer to adopt? Why?</p> <p>d) What is the objective of establishing the exterior orientation for a given image? List the exterior orientation parameters that we usually solve for. What are the alternative methodologies for deriving the exterior orientation parameters of an imaging system? Which one would you prefer to adopt? Why?</p>	2 2 4 4	

10.	<p>a) A GNSS receiver is better than a GPS receiver. Do you agree with this statement? Why?</p> <p>b) What is meant by x-parallax and y-parallax in stereo-images?</p> <p>c) Could the following matrix be considered a rotation matrix? Why?</p> $\begin{bmatrix} -0.7071 & 0.7071 & 0 \\ 0.7071 & 0.7071 & 0 \\ 0 & 0 & 1 \end{bmatrix}$	2 2 3	
Total Marks:		100	